

Composites USA, Inc. - Fitting Standards

Fitting Style No.: SS-325
Order as Fitting: SS-325 - "D"

Material: Pure Guard SS
Options: Stainless bolt set
 Quick Clamps (Avail. <= 18")
 Actuation



Project Specifications: Standard Design & Materials, -6" w.c. Alternative flange arrangements
 Standard with A-36 steel rings, SS rings >48" diameter, Teflon seals, one plated bolt set and gasket

S L I D E G A T E D A M P E R

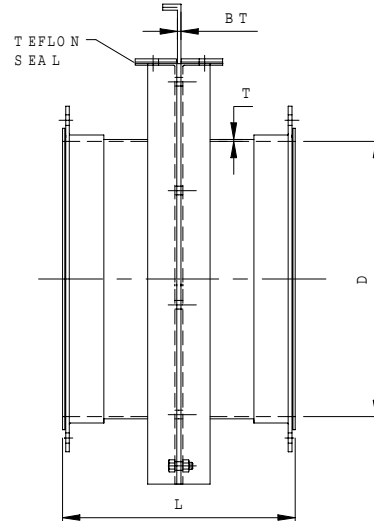
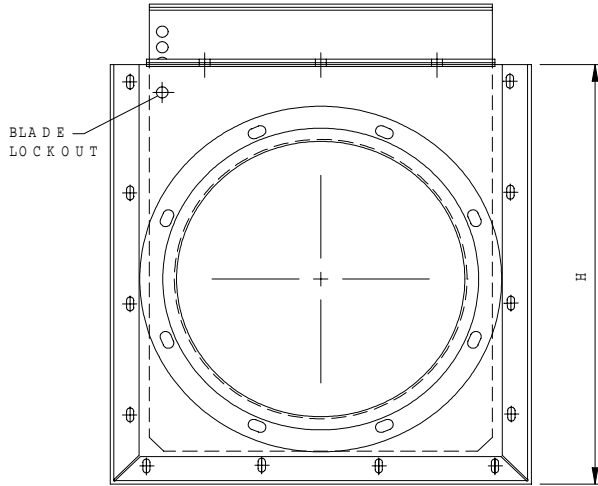

Diameter		Wall	Blade	Angle	Length	Overall	Diameter		Wall	Blade	Angle	Length	Overall
D		T	BT	Frame	L	H	D		T	BT	Frame	L	H
inches	mm	gage or inches		inches	inches	inches	inches	mm	gage or inches		inches	inches	inches
4	102	18 GA	18 GA	1.0	12	8	52	1321	14 GA	0.19	1.5	12	60
6	152	18 GA	18 GA			10	54	1372	14 GA	0.19			62
8	203	18 GA	18 GA			12	56	1422	14 GA	0.19			64
10	254	18 GA	18 GA			14	58	1473	12 GA	0.19			66
12	305	18 GA	18 GA			16	60	1524	12 GA	0.25			68
14	356	18 GA	18 GA			18	62	1575	12 GA	0.25			70
16	406	18 GA	18 GA			20	64	1626	12 GA	0.25			72
18	457	18 GA	18 GA			23	66	1676	12 GA	0.25			74
20	508	16 GA	18 GA	1.25	12	25	68	1727	12 GA	0.25	2	24	76
22	559	16 GA	16 GA			27	70	1778	12 GA	0.25			78
24	610	14 GA	16 GA			29	72	1829	12 GA	0.25			80
26	660	14 GA	16 GA			31	74	1880	12 GA	0.25			82
28	711	14 GA	14 GA			33	76	1930	12 GA	0.25			84
30	762	18 GA	14 GA			35	78	1981	12 GA	0.25			86
32	813	18 GA	14 GA			37	84	2134	11 GA	0.31			92
34	864	18 GA	12 GA			39	90	2286	11 GA	0.31			99
36	914	18 GA	11 GA	1.38	12	41	96	2438	10 GA	0.31	2.5	24	105
38	965	16 GA	11 GA			45	102	2591	10 GA	0.38			111
40	1016	16 GA	10 GA			47	108	2743	0.19	0.38			117
42	1067	16 GA	10 GA			49	114	2896	0.19	0.38			123
44	1118	16 GA	10 GA			51	120	3048	0.19	0.50			129
46	1168	14 GA	0.19			53	126	3200	0.19	0.50			135
48	1219	14 GA	0.19			56	132	3353	0.19	0.50			141