

Composites USA, Inc. - Fitting Standards

Fitting Style No.: SS-327
Order as Fitting: SS-327 - "D"

Material: Pure Guard SS
Options: Stainless bolt set
 Actuation
 Alternative flange arrangements



Project Specifications: Standard Design & Materials, -6" w.c.
 Standard with A-36 steel rings, SS rings >48" diameter, Teflon seals, one plated bolt set and gasket

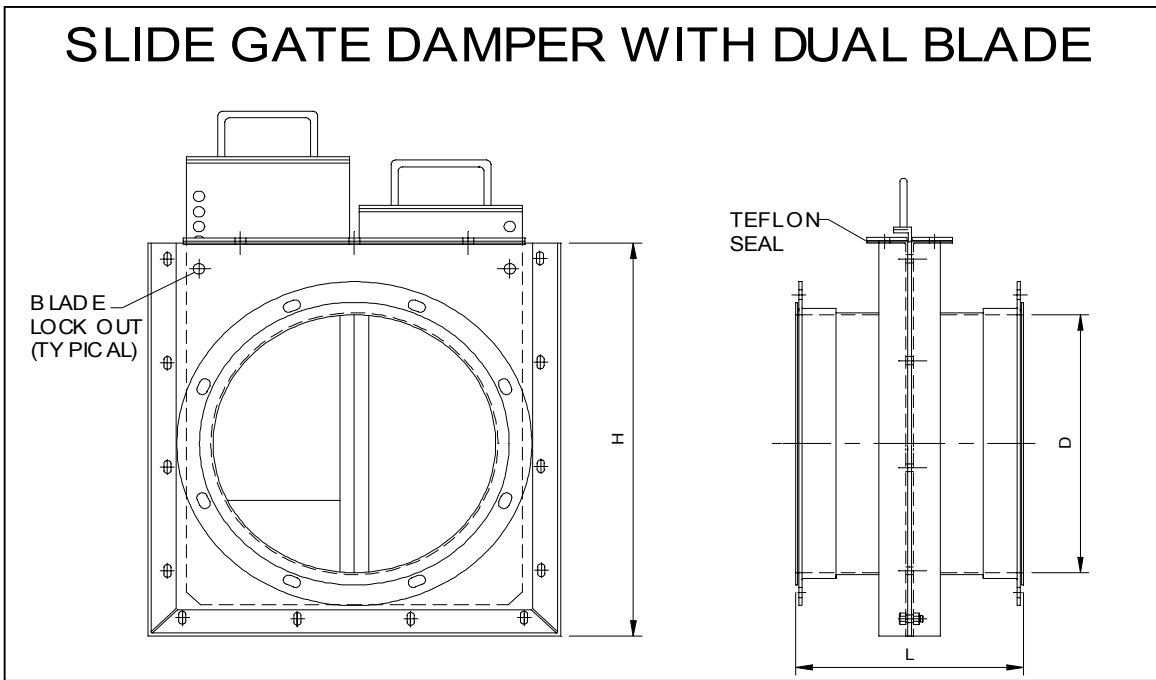

Diameter		Wall	Blade	Angle	Length	Overall	Diameter		Wall	Blade	Angle	Length	Overall
D		T	BT	Frame	L	H	D		T	BT	Frame	L	H
inches	mm	gage or inches		inches	inches	inches	inches	mm			inches	inches	inches
36	914	18 GA	16 GA	1.38	12	41	74	1880	12 GA	0.19	2	24	82
38	965	16 GA	16 GA			45	76	1930	12 GA	0.19			84
40	1016	16 GA	16 GA			47	78	1981	12 GA	0.19			86
42	1067	16 GA	14 GA			49	80	2032	12 GA	0.19			88
44	1118	16 GA	14 GA			51	82	2083	11 GA	0.19			90
46	1168	14 GA	14 GA			53	84	2134	11 GA	0.19			92
48	1219	14 GA	14 GA			56	86	2184	11 GA	0.19			94
52	1321	14 GA	14 GA			60	88	2235	11 GA	0.19			96
54	1372	14 GA	12 GA	1.5	12	62	90	2286	11 GA	0.19	2.5	24	99
56	1422	14 GA	12 GA			64	92	2337	11 GA	0.19			101
58	1473	12 GA	11 GA			66	94	2388	10 GA	0.25			103
60	1524	12 GA	11 GA			68	96	2438	10 GA	0.25			105
62	1575	12 GA	11 GA			70	102	2591	10 GA	0.25			111
64	1626	12 GA	11 GA			72	108	2743	0.19	0.25			117
66	1676	12 GA	10 GA			74	114	2896	0.19	0.25			123
68	1727	12 GA	10 GA			76	120	3048	0.19	0.25			129
70	1778	12 GA	10 GA			78	126	3200	0.19	0.31			135
72	1829	12 GA	0.19			80	132	3353	0.19	0.31			141